

Table of Contents

Multiplexing Reinstallation- under hood (53618-01-M) (2017 & beyond)3
Multiplexing installation – under hood (53618-02-M) (2017 & beyond).19

Two Piece Plug MPX Underhood Harness (53631-MPX) - 2017& Beyond



Multiplexing Wiring Reinstallation Under hood (2 plugs) (2017 & beyond)

(The control module installed under the hood)

53618-01-M

Link to Install MPX controller harness

<https://www.youtube.com/watch?v=siXbXHyrEKI>

Link to Install MPX light harness

https://www.youtube.com/watch?v=zu2OCCx_khE

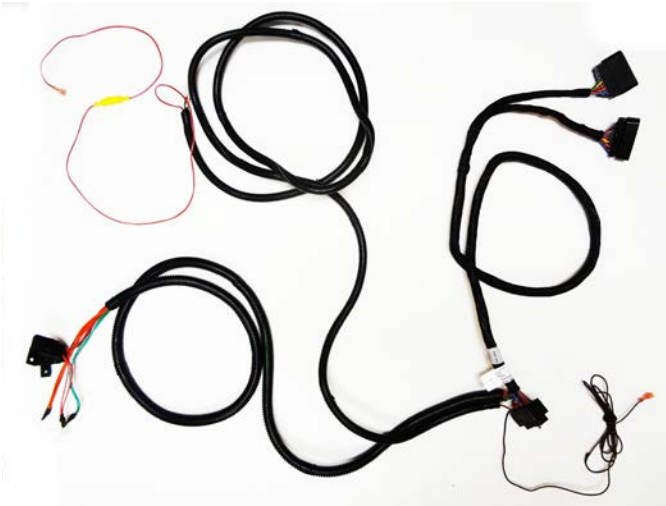

53631-MPX underhood MPX harness
(2 plugs)



53631-MPX (harness end view 2 plugs)



53629-B Lift frame harness (2 plugs)

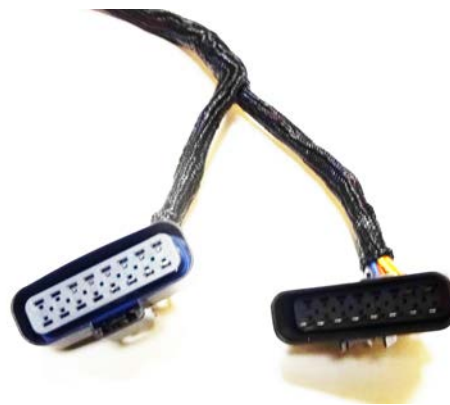

53629-B (harness end view 2 plugs)

Warning:

- Top of battery needs to be protected. If positive side of battery is accidentally grounded person could be burnt or wiring system can be damaged, or battery gasses could explode causing injuries.
- Disconnect cable from negative battery terminal before starting installation.
- Always wear eye protection and protective clothing when working around hydraulic systems.
- Remove jewelry and objects that might conduct electricity while working on power units.
- Fluid under pressure can pierce the skin and enter the bloodstream causing death or serious injury.
- Hydraulic hoses and electrical cables (harnesses) must be tied and routed safely to avoid any damage and pinching (away from hot places, sharp objects etc.).
- When drilling mounting holes or using self-tapping screws in the engine compartment, Ensure to check the mounting location for any wires, hoses other obstructions that could be damaged during installation.

Installation instructions

Note: Apply dielectric grease to all connections to prevent corrosion.

1. Ensure that there is no rust on the connections - the ground and power cable



2. Install the 2 x light harnesses (10) inside of the light housing. Ensure that there is no rust on any connections.

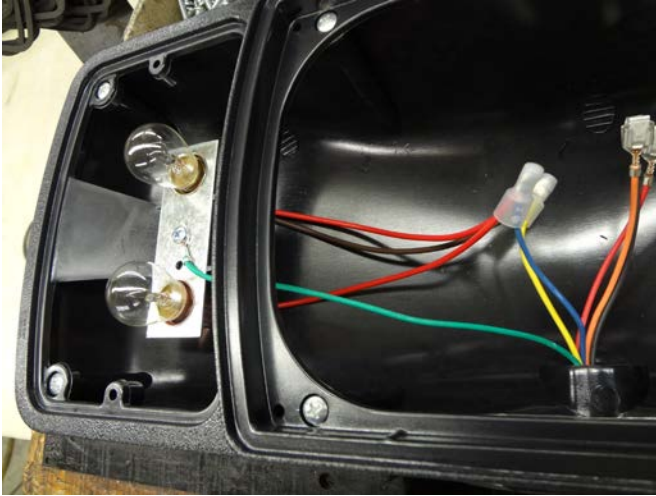

3. Secure the light harness as shown below. Install the lift frame harness (3) in the pump plate and secure it to the pump plate at the back. (if applicable)

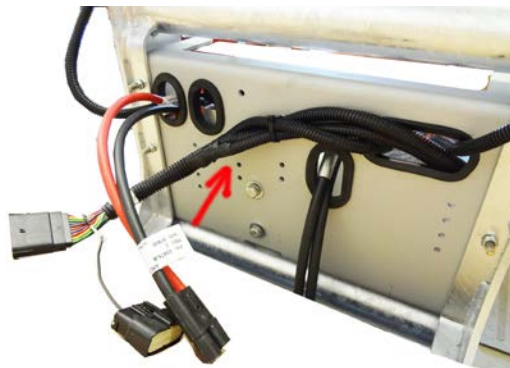
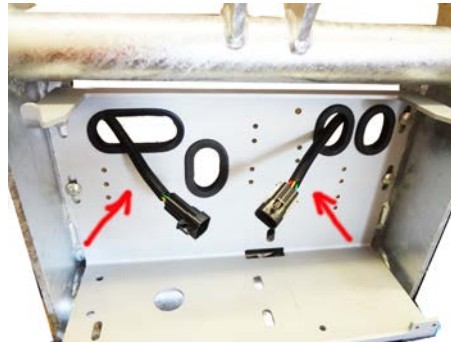

4. Plug the light harnesses to the lift frame harness (3) and secure them under the pump cover. (if applicable)
Attach the power unit leads from the lift frame harness to the coils as per instructions. Ensure that there is no rust on any connections. (see drawings below)

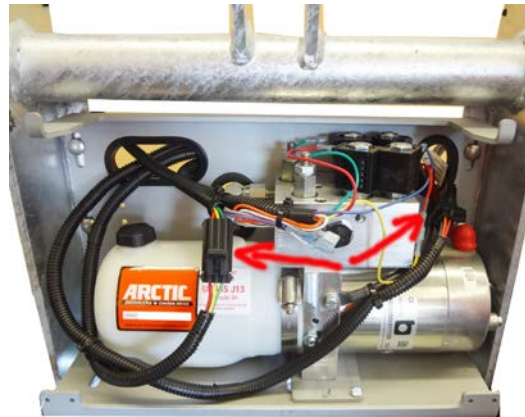

5. Mount a solenoid (4) to metal surface bending bracket if necessary. NOTE: Solenoid must be well grounded in order to function properly.



6. Install power cables as shown on the drawing below.
7. For the underhood harness (1) locate a pass through hole in the firewall near the driver's side of the truck. Route the harness through the hole in firewall and secure it under the dash and it should be attached to control station.
8. Connect all wires as shown on the drawing below.
9. Neatly secure all excess cables and wires using tie straps.

Note: Ensure all cables are properly protected from any sharp edges or hot or moving parts!!

Control Module Installation Instructions

Warning! When drilling mounting holes or using self-tapping screws in the engine compartment, Ensure to check the mounting location for any wires, hoses or other obstructions that could be damaged during installation.

When installing the Control Module, if possible mount inside the engine compartment (on the driver's side, if possible) locate a flat surface suitable for mounting the Control Module. Choose a surface that is clear of moving parts and extreme heat. The fire wall, fender well and radiator shroud are possible mounting locations.

Note: Make sure that chosen location is in a spot that will allow the wire harness (Vehicle Side & Lighting Harness) to reach their destination. Once location is determined, drill mounting holes and mount securely with bolts or use self-tapping screws. If an acceptable flat surface is not available, cable tie the control module securely to a harness or an existing bracket.

To avoid corrosions and extend the life of the Control module, keep connectors well-greased with dielectric grease.

(No service parts inside. Opening will break internal seal, damage module and may void warranty).

Installation of Vehicle Harness RED/WHITE (ignition) wire

Connect the RED/WHITE wire to a "keyed" 12V+ ignition source. Note: This 12V+ source should only be active when the key is in the ON position. Failure to wire to a "keyed" source can allow a condition to occur causing the battery to drain. This will also prevent operation of the plow without the vehicles key being on.

To find a "keyed" 12V+ ignition source, consult the fuse panel section of the vehicles owner's manual. Look for a fuse labeled ACC/IGN or ACC (Accessory). Remove the fuse, apply the fuse tap as shown below and reinstall the fuse. The RED/WHITE ignition wire can now be plugged to the ¼" fast-on tab.

Note: Check to make sure that the snowplow control ONLY has power when the vehicle ignition switch is ON.

If NO accessory fuse is available, a test light may have to be used to determine if power to a certain fuse (or any other power source) is "switched / keyed" or not.

Note: The RED/WHITE ignition wire is equipped with its own 10 amp fuse, so it can be tapped to any size fuse (10 or above). Do not use two taps on the same fuse.



Lighting System Procedure

To avoid corrosion, extend the life of the control module & ensure proper plow functionality keep all connectors well-greased with dielectric grease.

Basic Lighting Transfer Overview:

To transfer the lights from the vehicles headlights to the plow lights, the Control Module Electrical System installed on your vehicle must see or read four things.

- 1.) The vehicles ignition is turned ON.
- 2.) The vehicles headlight switch is turned ON.
- 3.) The plow is plugged in (by the vehicles grill).

Note: Keep in mind that turning the vehicles ignition OFF, acts as a RESET for the lighting system.

Below is a set of two conditions that may help to better explain the transfer of lights from vehicle to plow:

**When the vehicles ignition is turned OFF, the entire snowplow system is OFF. (Note: If this is not correct, see the plows installation instructions for proper plow installation).

Condition #1: The vehicle’s ignition is turned ON, the plow is NOT attached (and NOT plugged in) and the plow controller is OFF (or not plugged in). When turning ON the vehicles headlight switch, the vehicles headlights will turn ON.

Condition #2: The vehicles ignition is turned ON, the plow is attached (and plugged in) and the plow controller is OFF (or not plugged in). When turning ON the vehicles headlight switch, the plow headlights will turn ON.

53618-M-01 Multiplexing kit Underhood (for reinstalls)			
	Part#	Description	Quantity
1	53631-MPX	One Piece Harness (Truck side	1
2	800080-MPX	Control Module Box	1
3	53629-B	Lift Frame Harness	1
4	53614-N	1/4" Fuse Tab	1
5	53615-N	3/16" Fuse Tab	1
6	HH-00455-007	#8x3/4 SQ. DR. PAN	4
7	761321	3/16" Spade Connector	1
8	53608-N	Circuit Breaker	1
9	51335-56-M	Battery Cable, 56"	1
10	421061-02	Light harness	2

Arctic Equipment Manufacturing Corporation reserves the right under its product improvement policy to change construction or design details and furnish equipment when so altered without reference to illustrations or specifications used.

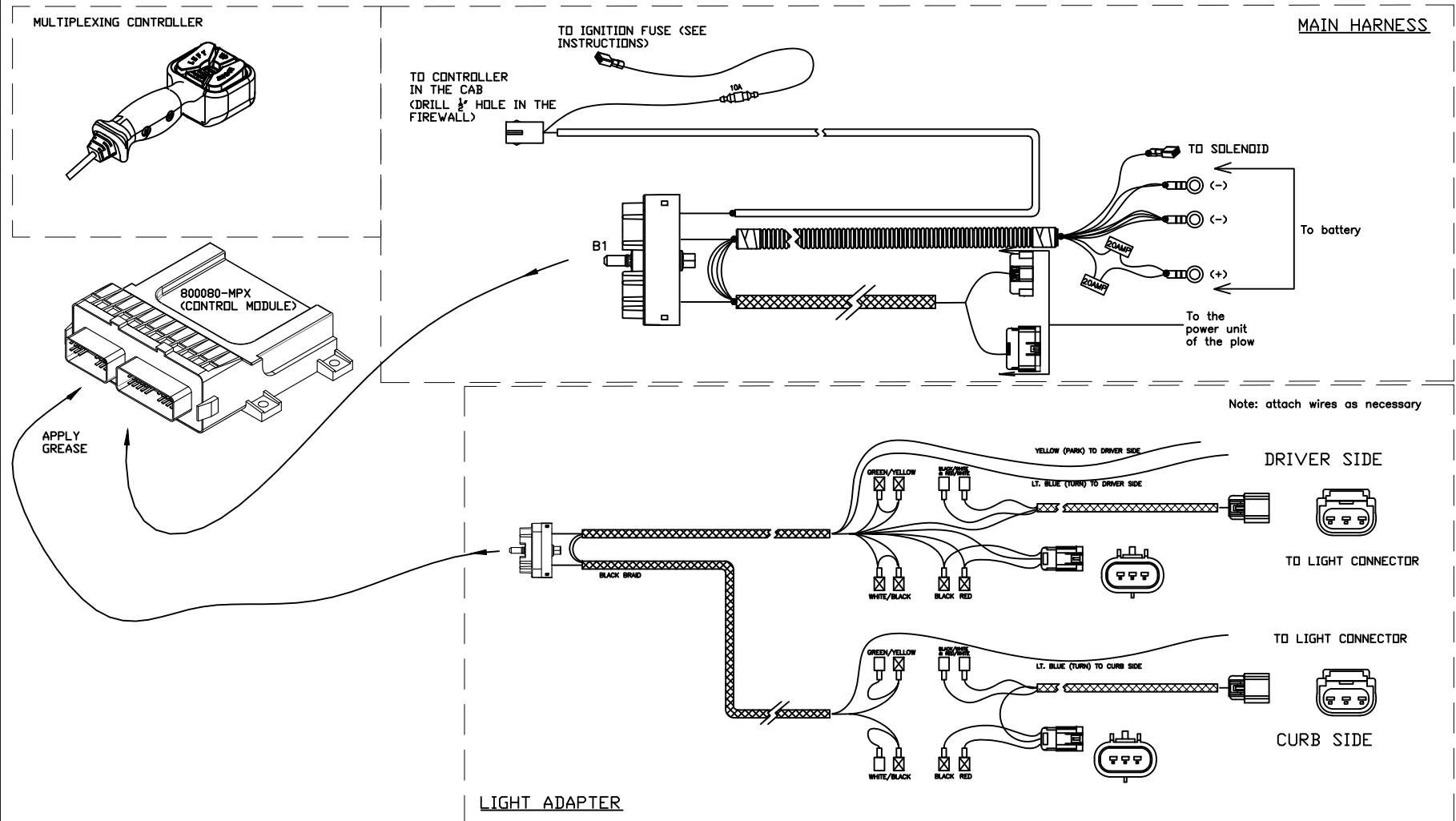

To avoid corrosions and extend the life of the Control module, keep connectors well-greased with dielectric grease.

MULTIPLEXING CONTROLLER:

- 53282-MPX (straight blade)
- 53326-MPX (V Plow)
- 53495-MPX (Wing blade)

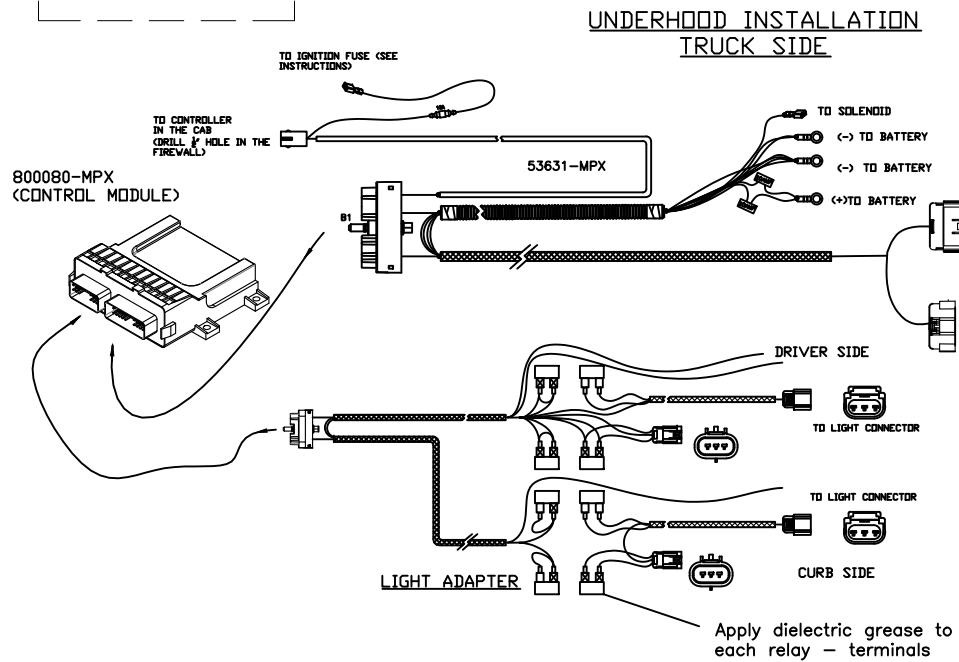
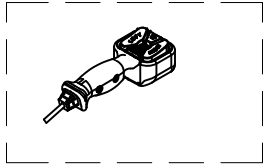

For reinstallations only (if the old light is used, this harness must be changed with the harness provided in the kit 53618-01-M - be sure to clean any rust inside OF the plow light when the new harness is installed).

UNDERHOOD INSTALLATION PLOW SIDE

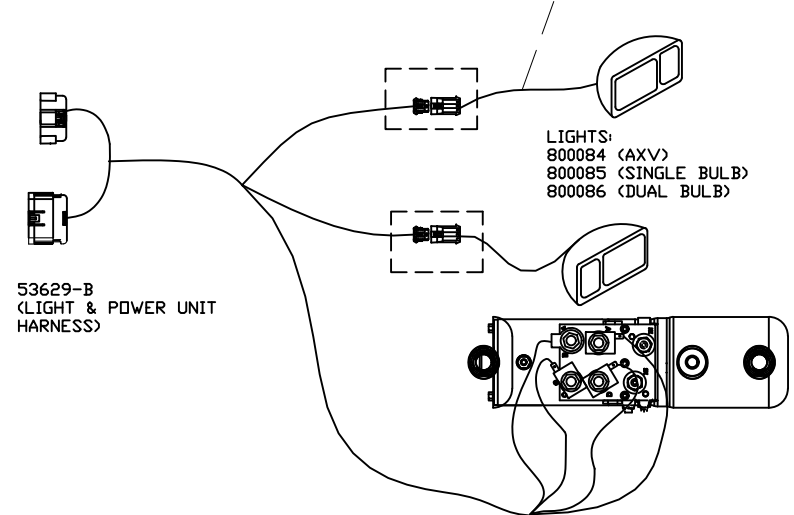

CONTROL MODULE, MAIN HARNESS AND LIGHT ADAPTER – UNDERHOOD INSTALLATION

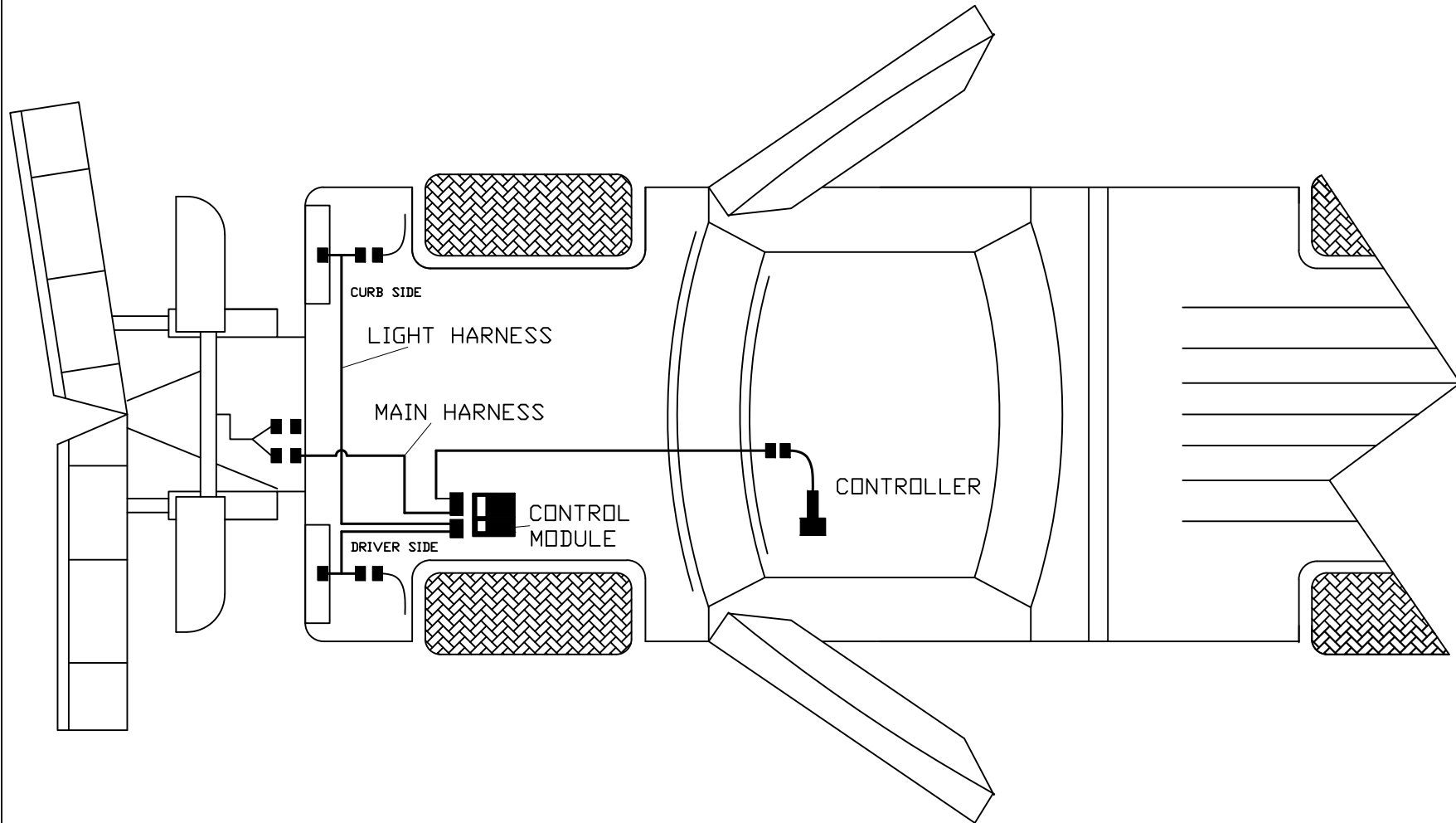

Under the vehicle's hood

Inside the vehicle's cab

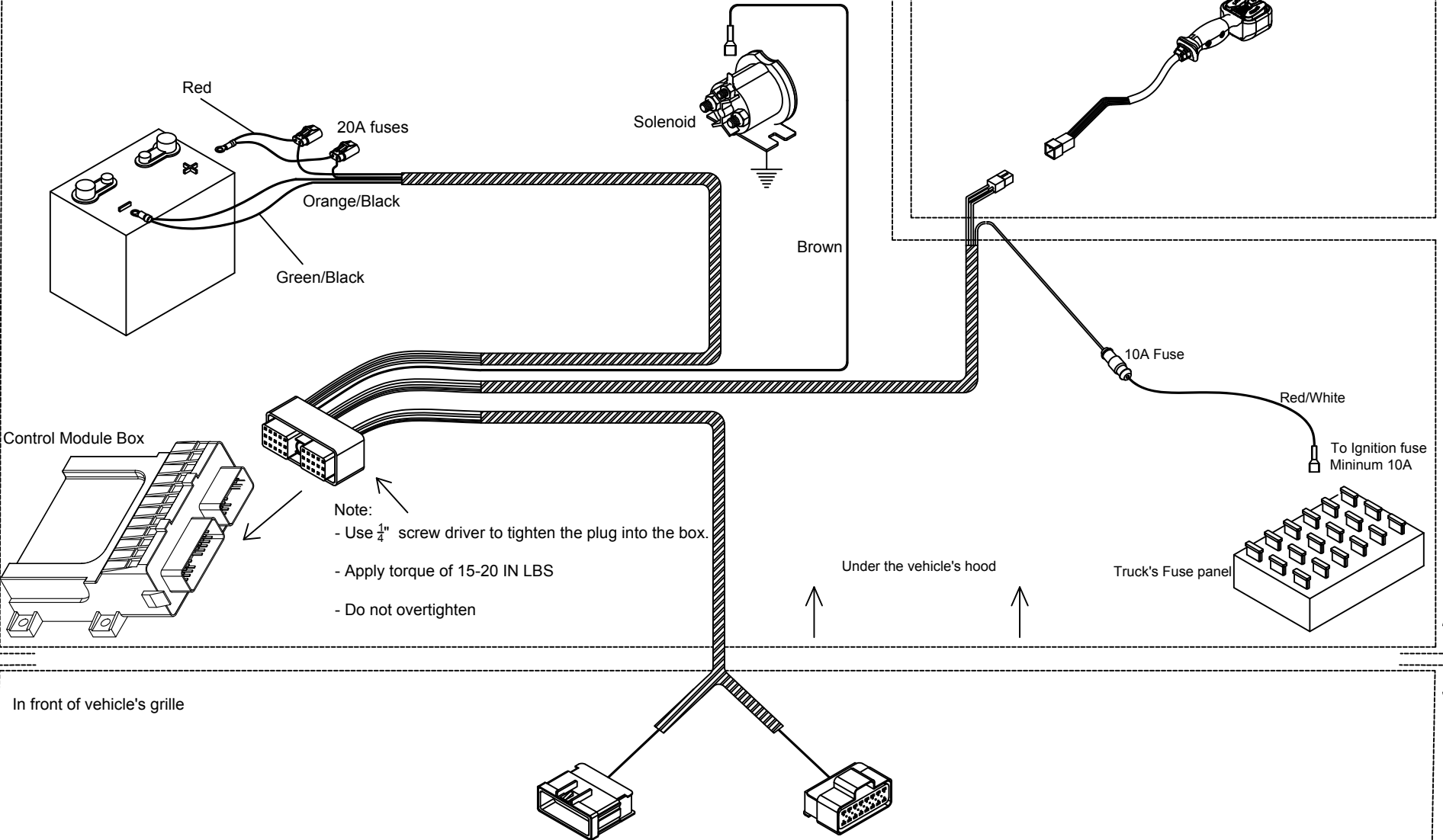

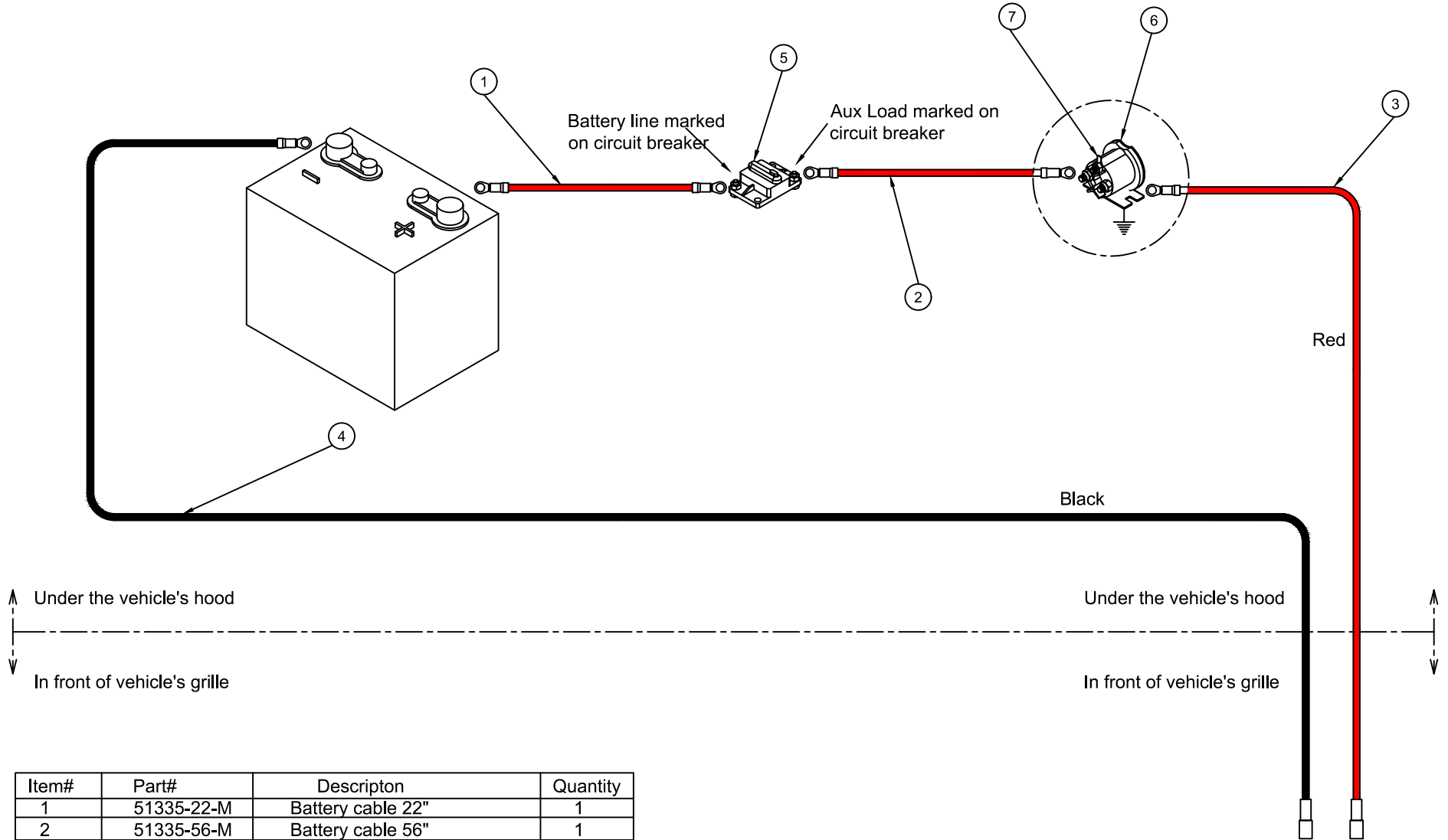

Item#	Part#	Description	Quantity
1	51335-22-M	Battery cable 22"	1
2	51335-56-M	Battery cable 56"	1
3	53478-B	90" Power cable	1
4	53477-B	90" Ground cable	1
5	53608-N	135 amps circuit breaker	1
6	FP17757	Solenoid	1
7	FP3414	#10 Blade terminal (Solenoid)	1

Inside the power unit cover

To the vehicle's grille

Installation to be done inside the power unit cover

CS

DS

To power unit coils

Plugs together when not in use A
(Apply grease)



CS Plow Headlight

DS Plow Headlight

Straight Blade		V Blade		Wing Blade	
Valve	Wire	Valve	Wire	Valve	Wire
A	Green	A1	Gray	A	White/Black
B	Yellow	A2	Green	B	Blue
C	Blue	B	Orange	C	Green
D	Red	C	Blue	D	Yellow
		D1	Purple	E	Red
		D2	Red	F	Orange
		E	Yellow	G	Gray
				H	Purple

Unused wires should be tied together

Inside the power unit cover

To the vehicle's grille

LEGEND

DS - Driver Side
CS - Curb Side

Straight Blade

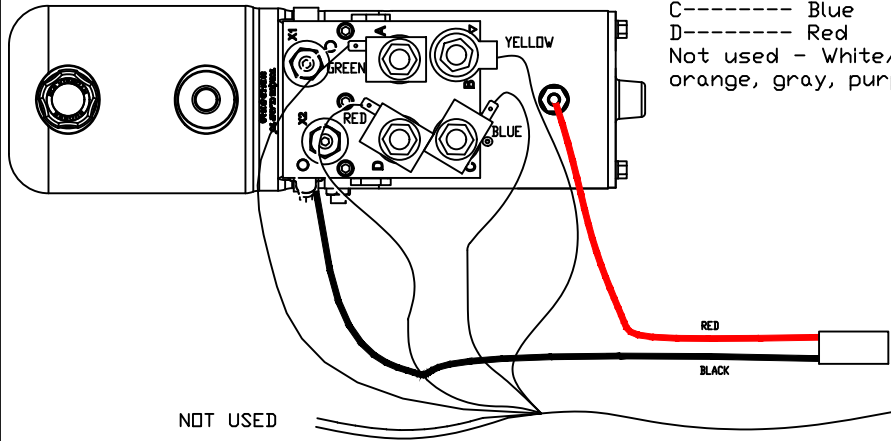

Lift frame harness

Valve	Wire
A-----	Green
B-----	Yellow
C-----	Blue
D-----	Red
Not used - White/black orange, gray, purple	

Wing Blade

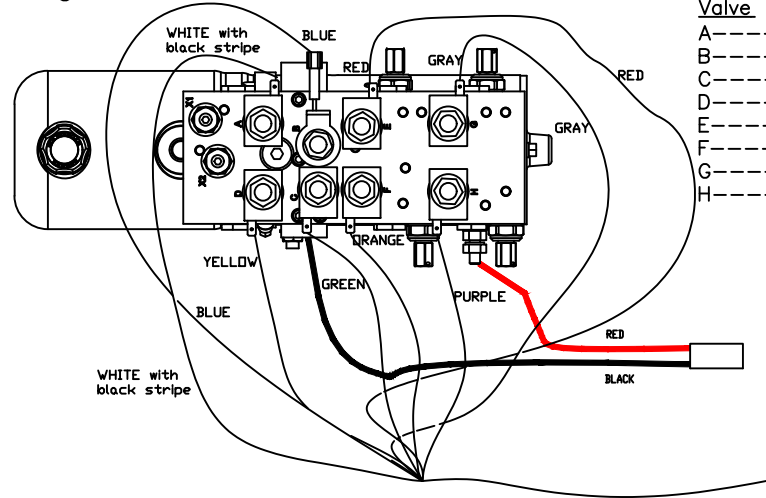

Lift frame harness

Valve	Wire
A-----	White/black
B-----	Blue
C-----	Green
D-----	Yellow
E-----	Red
F-----	Orange
G-----	Gray
H-----	Purple

V Blade

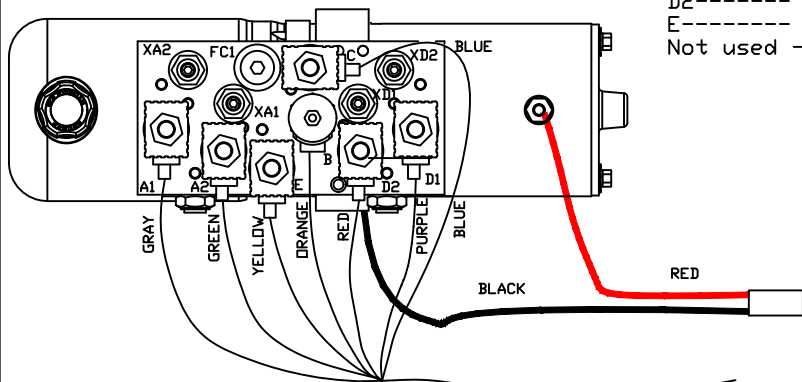

Lift frame harness

Valve	Wire
A1-----	Gray
A2-----	Green
B-----	Orange
C-----	Blue
D1-----	Purple
D2-----	Red
E-----	Yellow
Not used - White/black	

Note:

- To avoid corrosion, keep connectors well greased with dielectric grease
- Apply grease on the coils and on the connectors that plugs into the coils

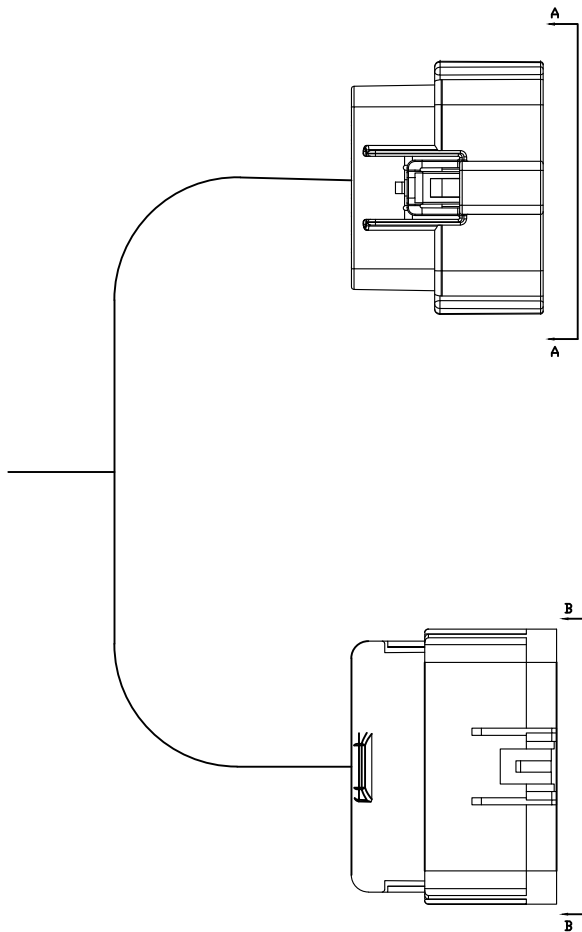

LEGEND: - PU power unit
 - DS driver side (light)
 - CS curb side (light)

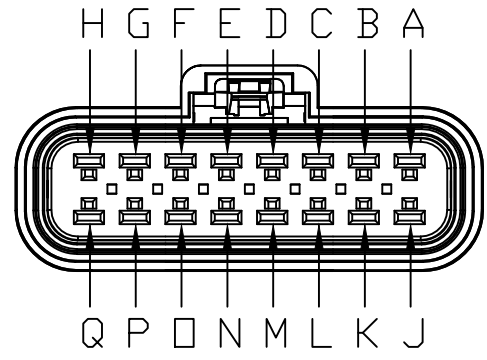

PIN FACE
 (FRONT VIEW A-A)

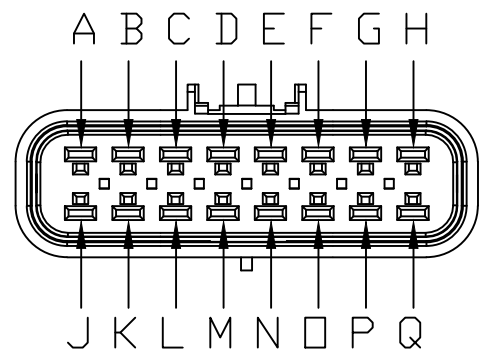

PIN FACE
 (FRONT VIEW B-B)

PIN #	COLOR	FUNCTION
A	BLACK	CS LOW BEAM
B	GREEN/BLACK	CS GROUND(Ring)
C	YELLOW	CS PARK
D	RED	CS HIGH BEAM
E	BLUE	OP9
F	ORANGE	OP3
G	VIOLET	OP2
H	GREY	OP1
J	Lt. BLUE	CS TURN
K	ORANGE/BLACK	CS GROUND(Ring)
L	CAVITY PLUG	N/A
M	CAVITY PLUG	N/A
N	CAVITY PLUG	N/A
O	CAVITY PLUG	N/A
P	CAVITY PLUG	N/A
Q	CAVITY PLUG	N/A

PIN #	COLOR	FUNCTION
A	CAVITY PLUG	N/A
B	CAVITY PLUG	N/A
C	CAVITY PLUG	N/A
D	CAVITY PLUG	N/A
E	GREEN	OP5
F	YELLOW	OP6
G	WHITE/BLACK	OP7
H	RED	OP8
J	CAVITY PLUG	N/A
K	CAVITY PLUG	N/A
L	GREEN/BLACK	DS GROUND(Ring)
M	YELLOW	DS PARK
N	RED	DS HIGH BEAM
O	ORANGE/BLACK	DS GROUND(Ring)
P	Lt. BLUE	DS TURN
Q	BLACK	DS LOW BEAM

Connectors alignment for the MPX system

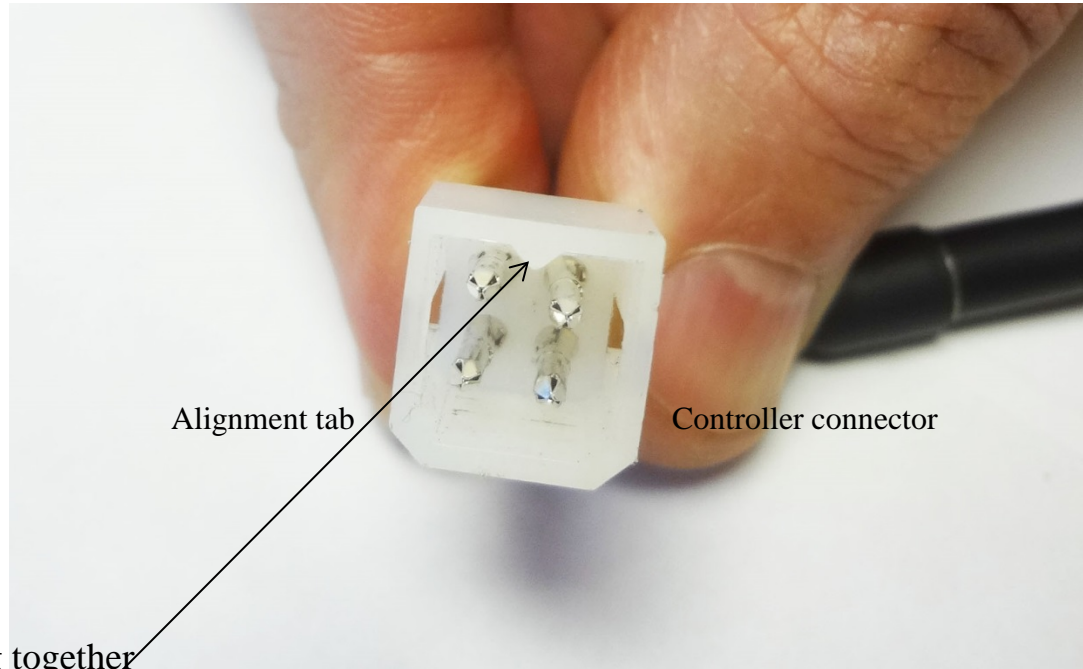

Must align before plugging together

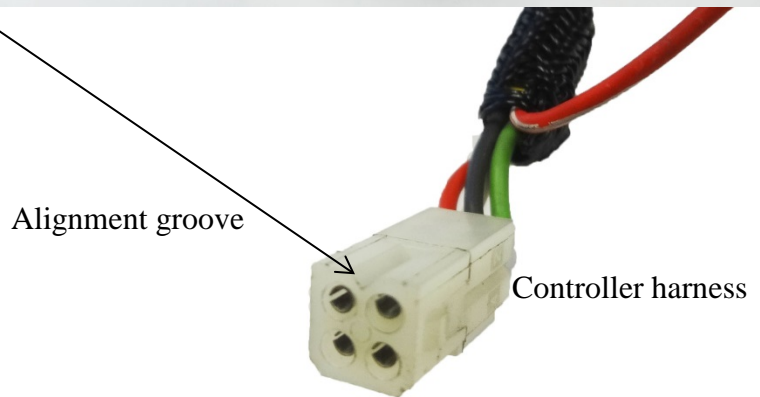

Multiplexing Wiring New Installation Under hood (2 plugs) (2017 & beyond)

(The control module installed under the hood – new installs)

53618-02-M

Link to Install MPX controller harness

<https://www.youtube.com/watch?v=siXbXHyrEKI>

Link to Install MPX light harness

https://www.youtube.com/watch?v=zu2OCCx_khE

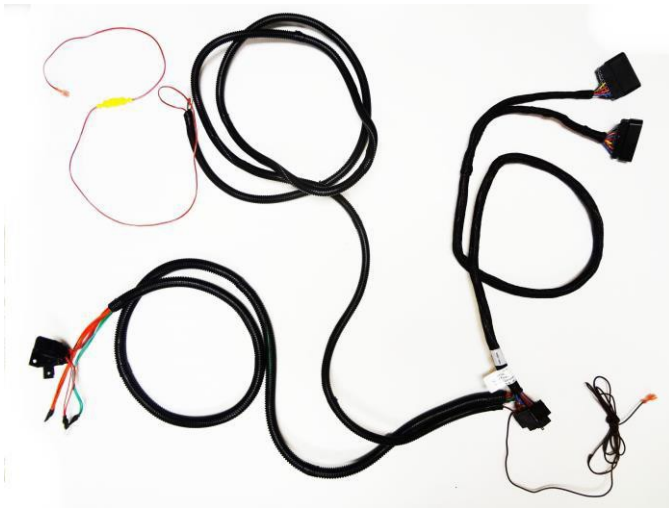

53631-MPX underhood MPX harness (2 plugs)



53631-MPX (harness end view 2 plugs)



53629-B Lift frame harness (2 plugs)

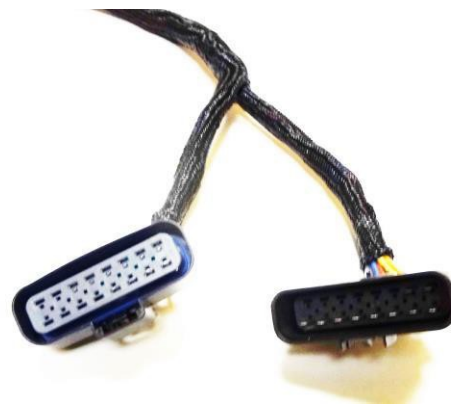

53629-B (harness end view 2 plugs)

Warning:

- Top of battery needs to be protected. If positive side of battery is accidentally grounded person could be burnt or wiring system can be damaged, or battery gasses could explode causing injuries.
- Disconnect cable from negative battery terminal before starting installation.
- Always wear eye protection and protective clothing when working around hydraulic systems.
- Remove jewelry and objects that might conduct electricity while working on power units.
- Fluid under pressure can pierce the skin and enter the bloodstream causing death or serious injury.
- Hydraulic hoses and electrical cables (harnesses) must be tied and routed safely to avoid any damage and pinching (away from hot places, sharp objects etc.).
- When drilling mounting holes or using self-tapping screws in the engine compartment, be sure to check the mounting location for any wires, hoses other obstructions that could be damaged during installation.

Installation instructions

Note: Apply dielectric grease to all connections to prevent corrosion.

1. Install the power unit that the motor is facing toward driver's side of truck. Secure the power unit to the back of pump plate using 3/8" bolt, lockwasher and flatwasher (18)(19)(20) (apply removable grade Loctite to 3/8" bolts to fasten power unit to the pump plate).

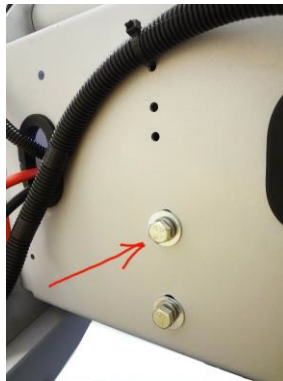

Install Pump Plate using 5/16" carriage bolts.

If M3493 is installed On Hi Boy Lift frame, install spacer plate and secure it with 1/4" bolt.

2. Install a red terminal protector (8) on a cable and plug assembly (1). Attach a red lead of the cable and plug assembly to the positive motor stud and a black lead to the pump base using 5/16" bolt and lockwasher (13)(14). Liberally coat connections with dielectric grease then slide cover over the eye on the end of the cable.



3. Install lights on a lift frame (15)(16)(17) and route a light harness inside of power unit housing. (using cable ties secure light harnesses to the lift frame)

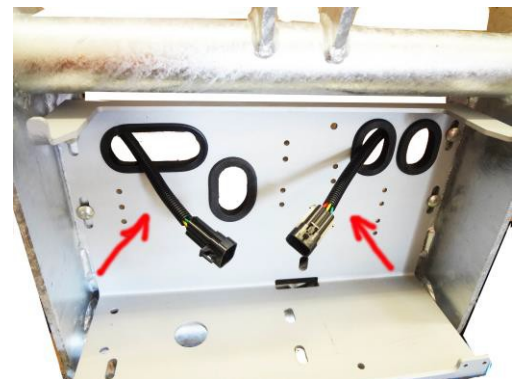

4. Install the lift frame harness (23), inserting through the curb side opening in the pump plate and security it to the pump plate at the back. Bring the harness toward driver side.

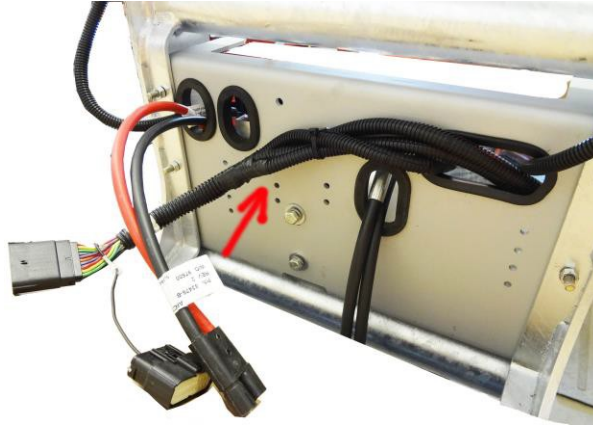

5. Plug the light harnesses to the lift frame harness (23) and secure them under the pump cover. Attach the power unit leads from the lift frame harness (23) to the coils as per instructions. (see drawings below)

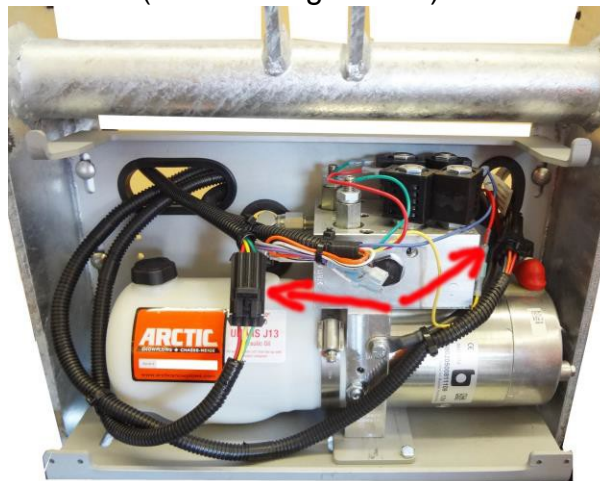

6. Mount a solenoid (4) to metal surface bending bracket if necessary. NOTE: Solenoid must be well grounded in order to function properly.

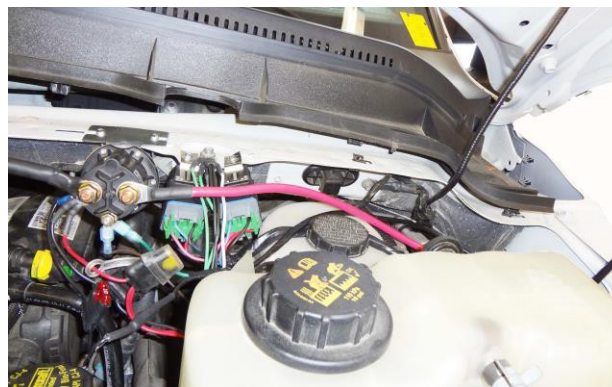

- Slide Dummy Plug (9) over power cable (3) and ground cable (2) and route through grille of truck leaving sufficient length to attach to the cable and plug assembly (1). Secure the red power cable (3) to the large terminal on the solenoid and the black ground cable (2) to the negative terminal on the battery. (as shown on the drawing below)

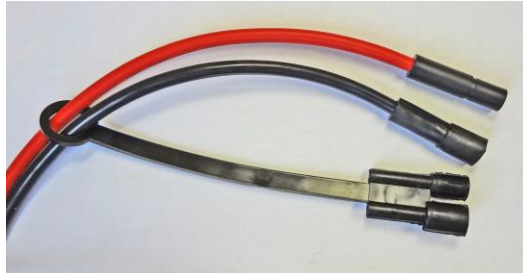

- Install power cable 22" (6) from the positive side of a battery to one of the terminal of 135 AMP circuit breaker (7). Install 56" power cable (5) on the second terminal end on the circuit breaker terminal and to the large terminal on the solenoid (4). When installing the circuit breaker locate a flat surface suitable for mounting. Choose surface that is clear of moving parts and extreme heat. The firewall or fender are possible mounting locations. Use ¼" bolts and locknuts. If an acceptable flat surface is not available, cable tie the circuit breaker securely to a harness or an existing bracket. Note: Make sure that chosen location is in a spot that will allow the power cables to reach their destination (as shown on the drawing below).
- For the underhood harness (21) locate a pass through hole in the firewall near the driver's side of the truck. Route the harness through the hole in firewall and secure it under the dash and it should be attached to control station.
- Connect all wires as shown on the drawing below.

Neatly secure all excess cables and wires using tie straps.
Note: Be sure all cables are properly protected from any sharp edges or hot or moving parts!!
- For hydraulic install refer to Hydraulic Installation section.

Control Module Installation Instructions

Warning! When drilling mounting holes or using self-tapping screws in the engine compartment, be sure to check the mounting location for any wires, hoses or other obstructions that could be damaged during installation.

When installing the Control Module, if possible mount inside the engine compartment (on the driver's side, if possible) locate a flat surface suitable for mounting the Control Module. Choose a surface that is clear of moving parts and extreme heat. The fire wall, fender well and radiator shroud are possible mounting locations.

Note: Make sure that chosen location is in a spot that will allow the wire harness (Vehicle Side & Lighting Harness) to reach their destination. Once location is determined, drill mounting holes and mount securely with bolts or use self-tapping screws. If an acceptable flat surface is not available, cable tie the control module securely to a harness or an existing bracket.

To avoid corrosions and extend the life of the Control module, keep connectors well-greased with dielectric grease.

(No service parts inside. Opening will break internal seal, damage module and may void warranty).

Installation of Vehicle Harness RED/WHITE (ignition) wire

Connect the RED/WHITE wire to a "keyed" 12V+ ignition source. Note: This 12V+ source should only be active when the key is in the ON position. Failure to wire to a "keyed" source can allow a condition to occur causing the battery to drain. This will also prevent operation of the plow without the vehicles key being on.

To find a "keyed" 12V+ ignition source, consult the fuse panel section of the vehicles owner's manual. Look for a fuse labeled ACC/IGN or ACC (Accessory). Remove the fuse, apply the fuse tap as shown below and reinstall the fuse. The RED/WHITE ignition wire can now be plugged to the ¼" fast-on tab.

Note: Check to make sure that the snowplow control ONLY has power when the vehicle ignition switch is ON.

If NO accessory fuse is available, a test light may have to be used to determine if power to a certain fuse (or any other power source) is "switched / keyed" or not.

Note: The RED/WHITE ignition wire is equipped with its own 10 amp fuse, so it can be tapped to any size fuse (10 or above). Do not use two taps on the same fuse.

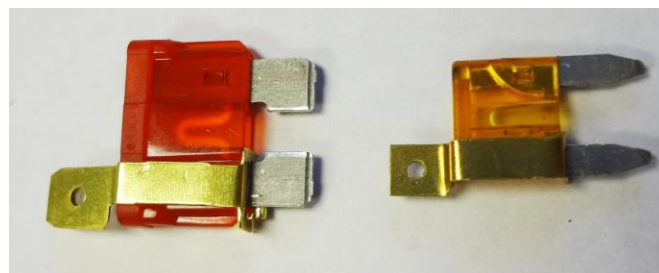

Lighting System Procedure

To avoid corrosion, extend the life of the control module & ensure proper plow functionality keep all connectors well-greased with dielectric grease.

Basic Lighting Transfer Overview

To transfer the lights from the vehicles headlights to the plow lights, the Control Module Electrical System installed on your vehicle must see or read four things.

- 1.) The vehicles ignition is turned ON.
- 2.) The vehicles headlight switch is turned ON.
- 3.) The plow is plugged in (by the vehicles grill).

Note: Keep in mind that turning the vehicles ignition OFF, acts as a RESET for the lighting system.

Below is a set of two Conditions that may help to better explain the transfer of lights from vehicle to plow:

**When the vehicles ignition is turned OFF, the entire snowplow system is OFF. (Note: If this is not correct, see the plows installation instructions for proper plow installation).

Condition #1: The vehicle's ignition is turned ON, the plow is NOT attached (and NOT plugged in) and the plow controller is OFF (or not plugged in). When turning ON the vehicles headlight switch, the vehicles headlights will turn ON.

Condition #2: The vehicles ignition is turned ON, the plow is attached (and plugged in) and the plow controller is OFF (or not plugged in). When turning ON the vehicles headlight switch, the plow headlights will turn ON

Parts can be found in the hydraulic pump kit			
	Part#	Description	Quantity
1	53476-B	18" Cable Plug Assembly	1
2	53477-B	90" Ground Cable (Black)	1
3	53478-B	90" Power Cable (Red)	1
4	FP17757	Solenoid	1
5	51335-56-M	Battery Cable, 56"	1
6	51335-22-M	Gauge Battery Cable, 22"	1
7	53608-N	Circuit Breaker	1
8	52427-N	Red Terminal Protector	1
9	53560-A	Dummy Plug (Power & Ground)	1
10	HH-00293-006	¼"-20x1 HHCS	1
11	HH-00294-001	¼"-20 Hex Nut	1
12	HH-00457-006	¼" Lockwasher	1
13	HH-00293-026	5/16"-18x3/4 HHCS	1
14	HH-00457-007	5/16" Lockwasher	1
15	800084	Sealed Beam AXV light Kit	1
16	800085	Single Bulb Head light Kit	1
17	800086	Dual bulb head light kit	1
18	HH-00293-049	3/8-16x1 HHCS	2
19	HH-00457-004	3/8 Lockwasher	2
20	HH-00341-004	3/8 Flatwasher	2

53618-02-M Multiplexing kit Underhood (for brand new installs)			
	Part#	Description	Quantity
21	53631-MPX	One Piece Harness (Truck	1
22	800080-MPX	Control Module Box	1
23	53629-B	Lift Frame Harness	1
24	53614-N	1/4" Fuse Tab	1
25	53615-N	3/16" Fuse Tab	1
26	HH-00455-007	#8x3/4 SQ. DR. PAN	4
27	761321	3/16" Spade Connector	1

Arctic Equipment Manufacturing Corporation reserves the right under its product improvement policy to change construction or design details and furnish equipment when so altered without reference to illustrations or specifications used.

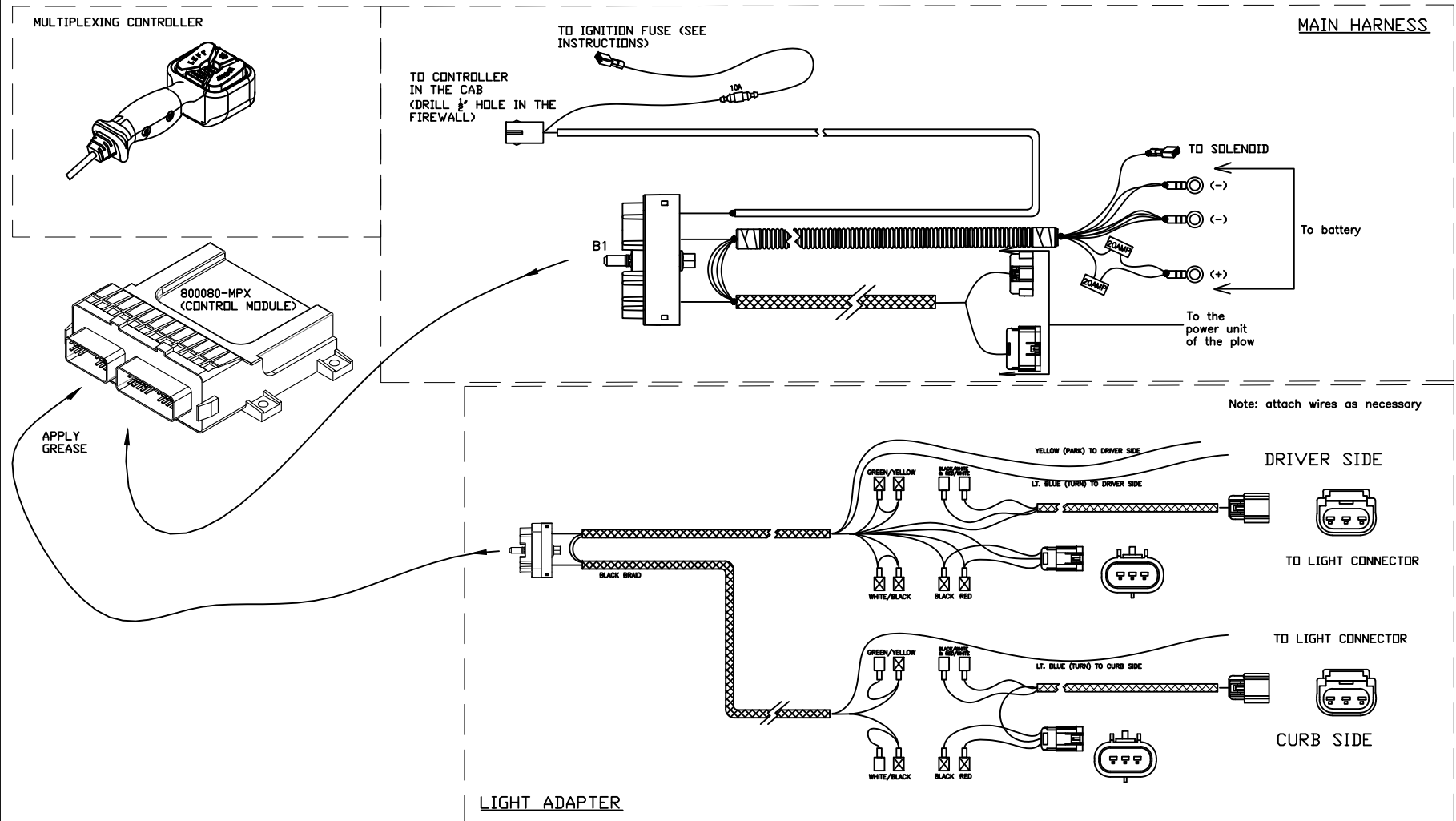

To avoid corrosions and extend the life of the Control module, keep connectors well-greased with dielectric grease.

MULTIPLEXING CONTROLLER:

- 53282-MPX (straight blade)
- 53326-MPX (V Plow)
- 53495-MPX (Wing blade)

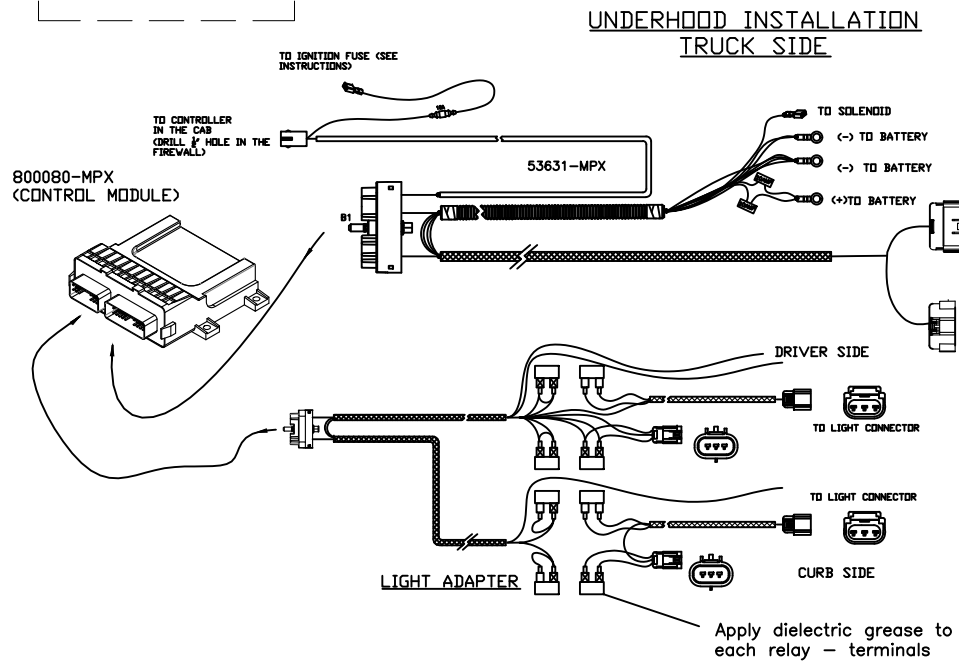
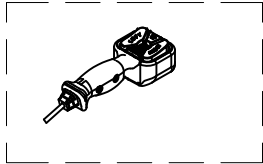

For reinstallations only (if the old light is used, this harness must be changed with the harness provided in the kit 53618-01-M - be sure to clean any rust inside OF the plow light when the new harness is installed).

UNDERHOOD INSTALLATION PLOW SIDE

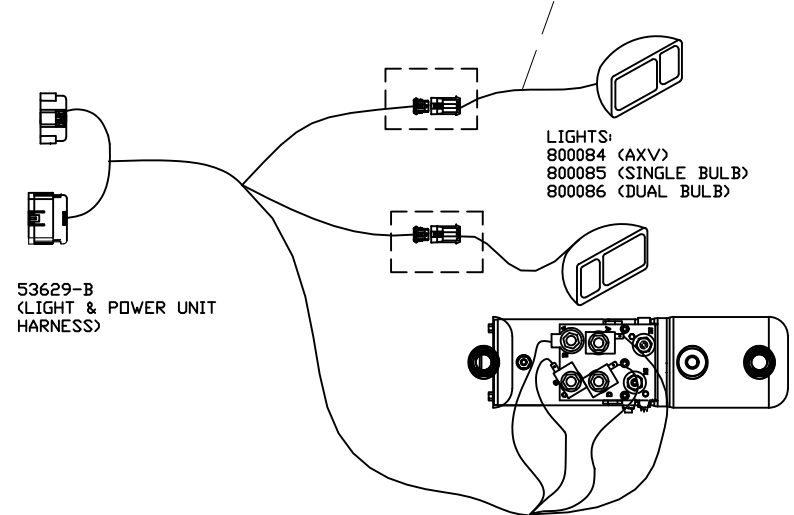

CONTROL MODULE, MAIN HARNESS AND LIGHT ADAPTER – UNDERHOOD INSTALLATION

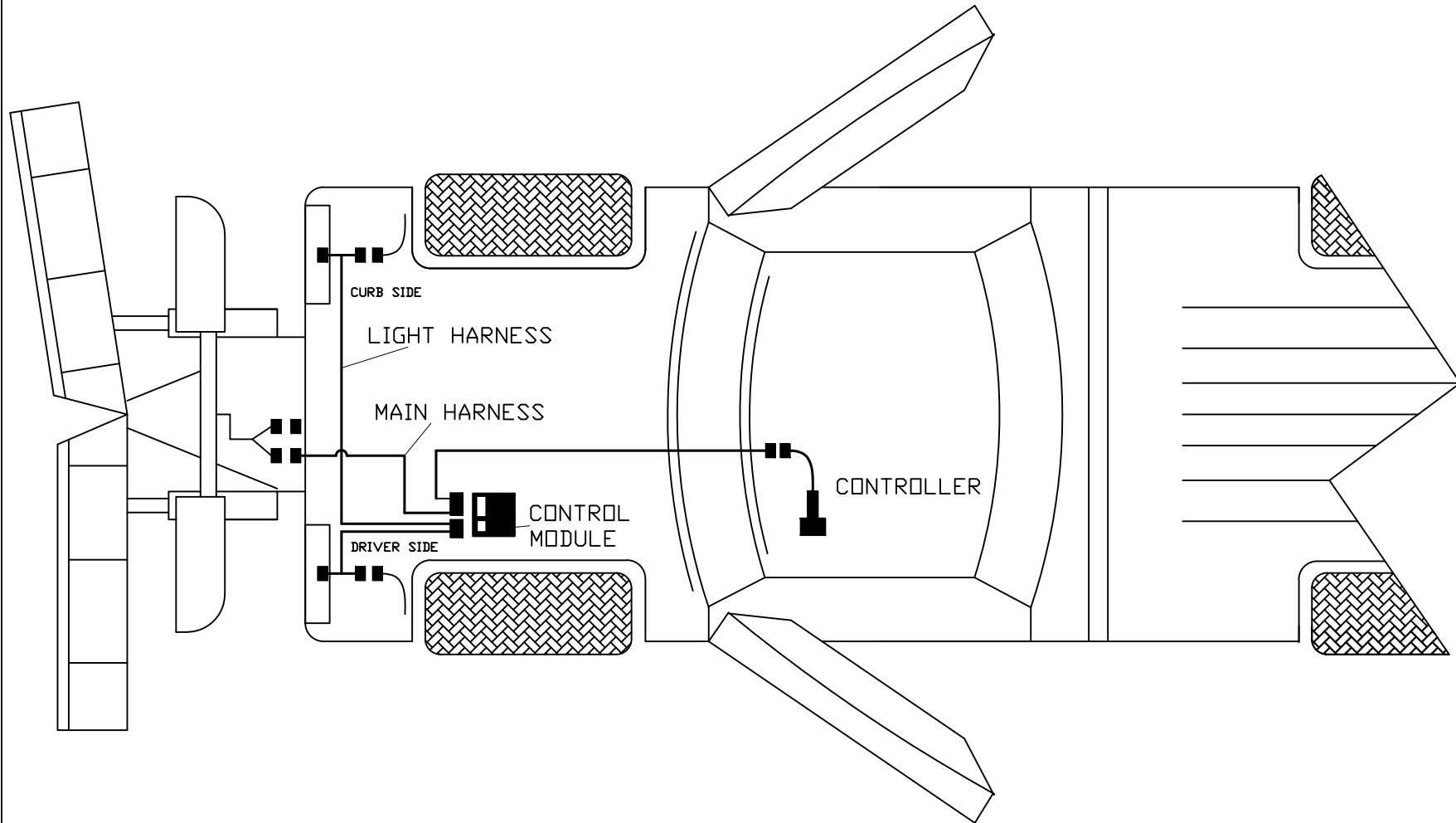

Under the vehicle's hood

Inside the vehicle's cab

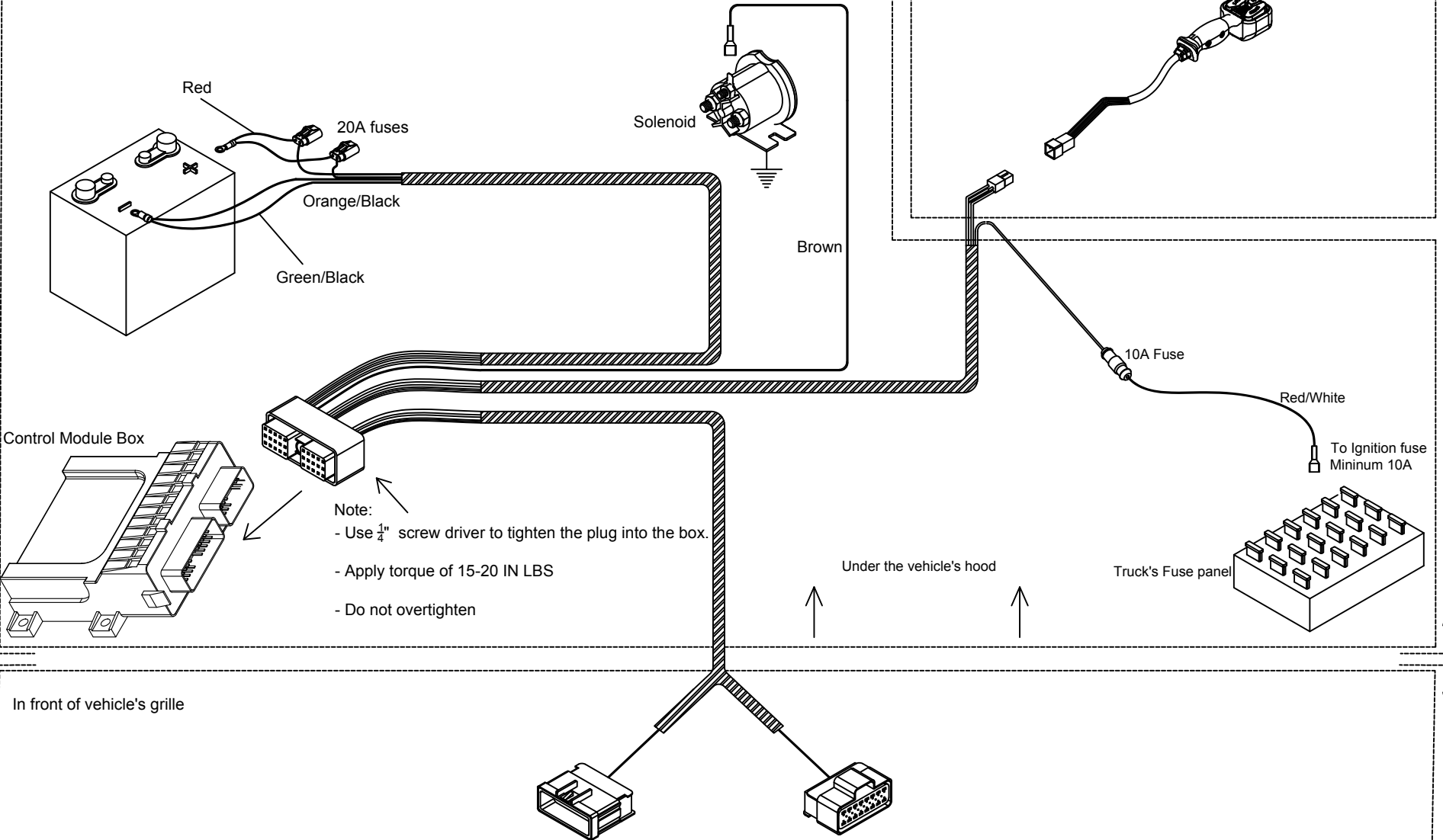

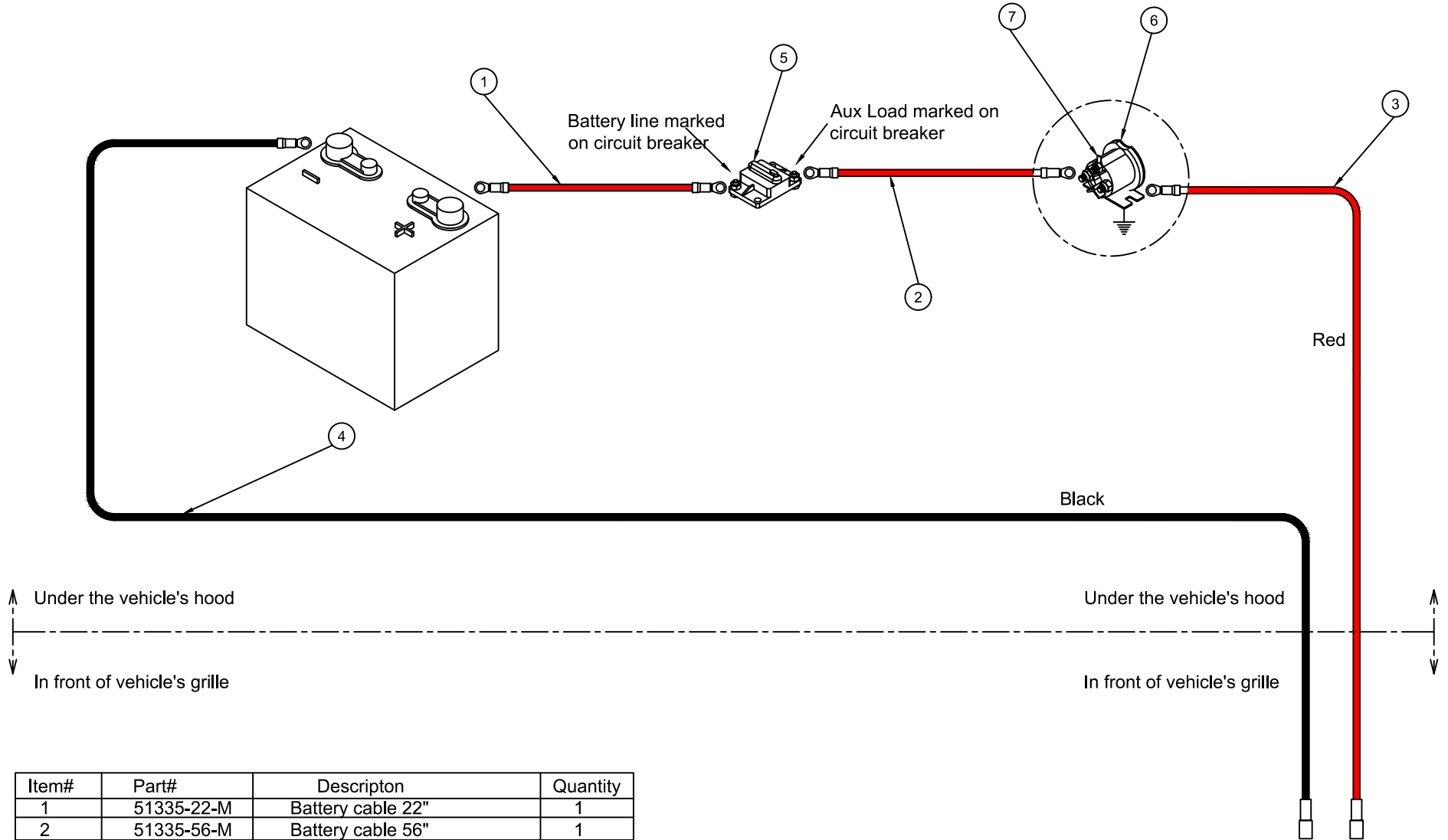

Item#	Part#	Description	Quantity
1	51335-22-M	Battery cable 22"	1
2	51335-56-M	Battery cable 56"	1
3	53478-B	90" Power cable	1
4	53477-B	90" Ground cable	1
5	53608-N	135 amps circuit breaker	1
6	FP17757	Solenoid	1
7	FP3414	#10 Blade terminal (Solenoid)	1

Inside the power unit cover

To the vehicle's grille

Installation to be done inside the power unit cover

CS

DS

To power unit coils

Plugs together when not in use A
(Apply grease)



CS Plow Headlight

DS Plow Headlight

Straight Blade		V Blade		Wing Blade	
Valve	Wire	Valve	Wire	Valve	Wire
A	Green	A1	Gray	A	White/Black
B	Yellow	A2	Green	B	Blue
C	Blue	B	Orange	C	Green
D	Red	C	Blue	D	Yellow
		D1	Purple	E	Red
		D2	Red	F	Orange
		E	Yellow	G	Gray
				H	Purple

Unused wires should be tied together

Inside the power unit cover

To the vehicle's grille

LEGEND

DS - Driver Side
CS - Curb Side

Straight Blade

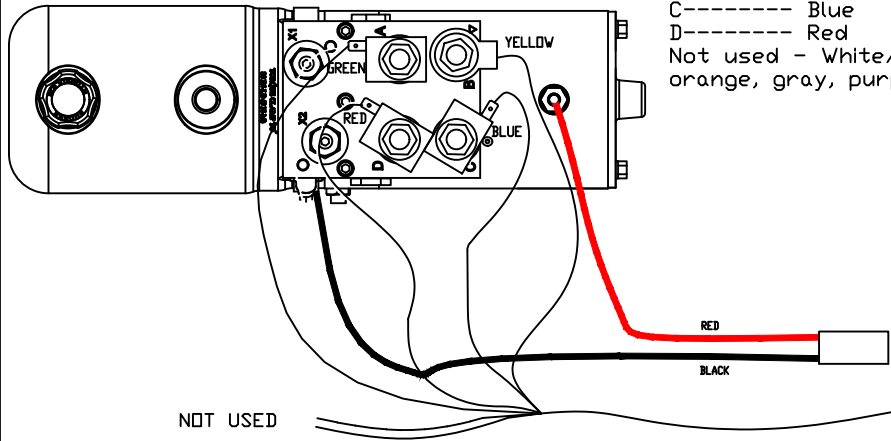

Valve	Wire
A-----	Green
B-----	Yellow
C-----	Blue
D-----	Red
Not used - White/black orange, gray, purple	

Lift frame harness

Wing Blade

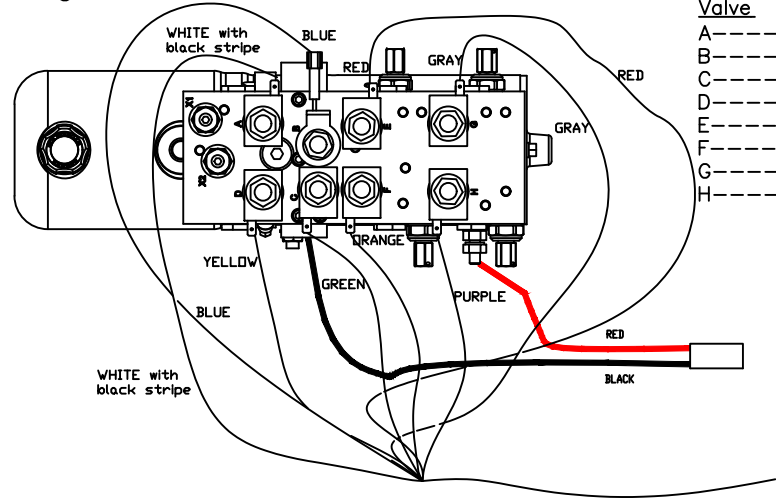

Valve	Wire
A-----	White/black
B-----	Blue
C-----	Green
D-----	Yellow
E-----	Red
F-----	Orange
G-----	Gray
H-----	Purple

Lift frame harness

V Blade

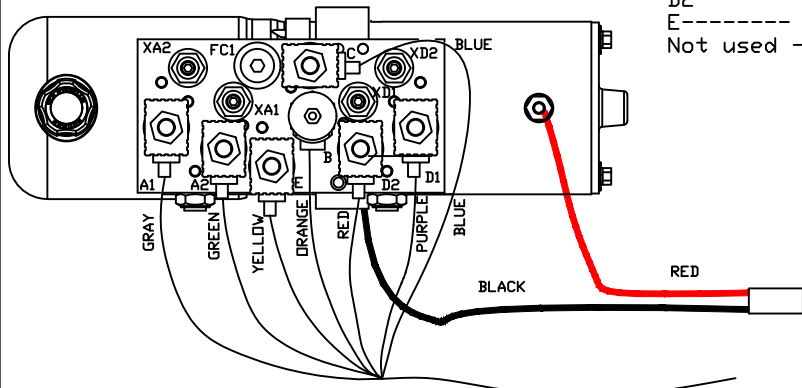

Valve	Wire
A1-----	Gray
A2-----	Green
B-----	Orange
C-----	Blue
D1-----	Purple
D2-----	Red
E-----	Yellow
Not used - White/black	

Lift frame harness

Note:

- To avoid corrosion, keep connectors well greased with dielectric grease
- Apply grease on the coils and on the connectors that plugs into the coils

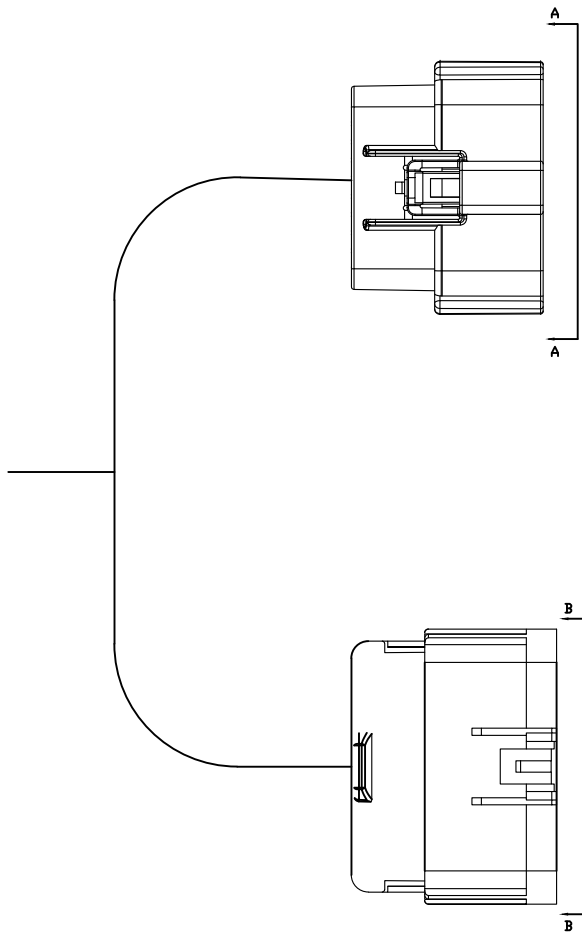

LEGEND: - PU power unit
 - DS driver side (light)
 - CS curb side (light)

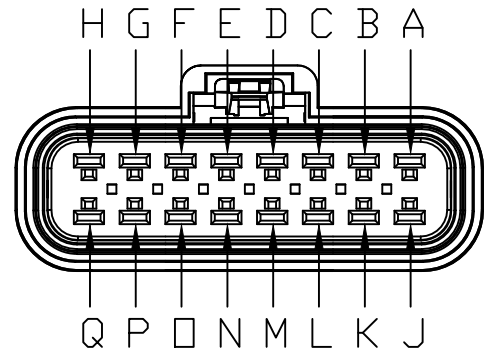

PIN FACE
 (FRONT VIEW A-A)

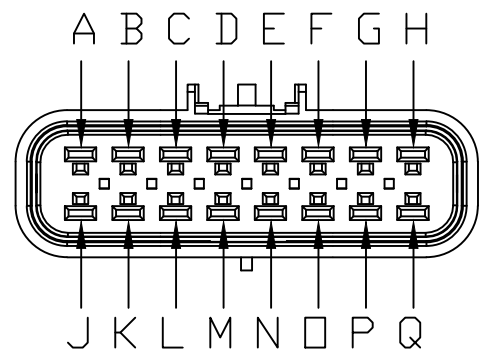

PIN FACE
 (FRONT VIEW B-B)

PIN #	COLOR	FUNCTION
A	BLACK	CS LOW BEAM
B	GREEN/BLACK	CS GROUND(Ring)
C	YELLOW	CS PARK
D	RED	CS HIGH BEAM
E	BLUE	OP9
F	ORANGE	OP3
G	VIOLET	OP2
H	GREY	OP1
J	Lt. BLUE	CS TURN
K	ORANGE/BLACK	CS GROUND(Ring)
L	CAVITY PLUG	N/A
M	CAVITY PLUG	N/A
N	CAVITY PLUG	N/A
O	CAVITY PLUG	N/A
P	CAVITY PLUG	N/A
Q	CAVITY PLUG	N/A

PIN #	COLOR	FUNCTION
A	CAVITY PLUG	N/A
B	CAVITY PLUG	N/A
C	CAVITY PLUG	N/A
D	CAVITY PLUG	N/A
E	GREEN	OP5
F	YELLOW	OP6
G	WHITE/BLACK	OP7
H	RED	OP8
J	CAVITY PLUG	N/A
K	CAVITY PLUG	N/A
L	GREEN/BLACK	DS GROUND(Ring)
M	YELLOW	DS PARK
N	RED	DS HIGH BEAM
O	ORANGE/BLACK	DS GROUND(Ring)
P	Lt. BLUE	DS TURN
Q	BLACK	DS LOW BEAM

Connectors alignment for the MPX system

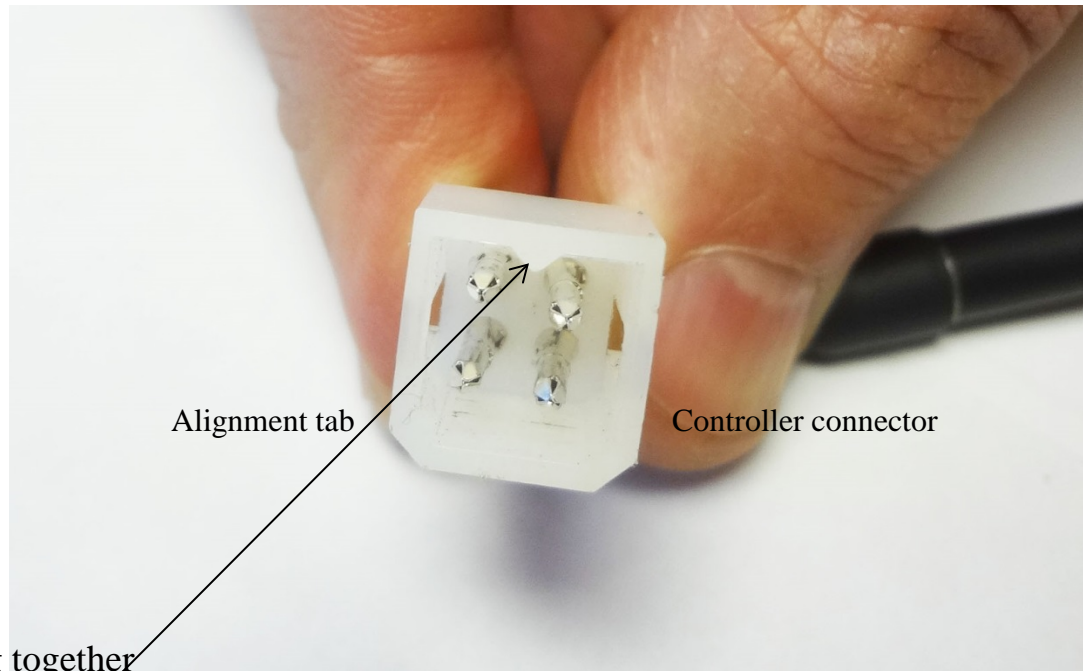

Must align before plugging together

